



Please paste the barcoded label here

TOTAL MARKS

NATIONAL SENIOR CERTIFICATE EXAMINATION
 MAY 2025

MATHEMATICAL LITERACY: PAPER II

EXAMINATION NUMBER

--	--	--	--	--	--	--	--	--	--	--	--	--	--

Time: 3 hours

150 marks

PLEASE READ THE FOLLOWING INSTRUCTIONS CAREFULLY

1. This question paper consists of:
 - 36 pages that includes 3 pages at the back.
 - An Insert of 2 pages (i–ii).
 - Five questions.
2. Please check that your question paper is complete.
3. Answer ALL FIVE questions.
4. **Answer ALL the questions on the question paper and hand this in at the end of the examination. Remember to write your examination number in the space provided on the question paper.**
5. A non-graphical, non-programmable calculator may be used.
6. ALL necessary calculations must be clearly shown.
7. Units of measurement must be included where applicable.
8. It is in your own interest to write legibly and to present your work neatly.
9. Maps and diagrams are not necessarily drawn to scale.
10. Three blank pages (page 34 to 36) are included at the end of the question paper. Use these pages if you run out of space for a question. Clearly indicate the number of the question you are answering should you use this additional space.

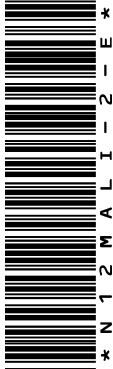

Question	1		2		3		4		5		Total	
	Marker	Mod.	Marker	Mod.	Marker	Mod.	Marker	Mod.	Marker	Mod.	Marker	Mod.
Mark												
Signature												
Total	33		34		38		32		13		150	

QUESTION 1

1.1 Stuart McDonald is a seven-year-old boy who loves playing with Lego blocks. He received the following Lego set from his parents for his birthday.



Packaging information	
Length	14 cm
Width	14 cm
Depth	1,2 cm
Weight	20 g

[Source: <<https://www.bobshop.co.za/lego-creator-30183-little-car>>]

Use the above information to answer the following questions.

1.1.1 Convert the given dimensions of the packaging for the following:

Length = _____ (metres)

Width = _____ (millimetres)

Depth = _____ (kilometres)

(3)

1.1.2 Convert the weight of the package to milligrams.

Weight of package = _____ (milligrams)

(2)

1.1.3 Stuart's dad is teaching Stuart about area and perimeter.

(a) Explain the meaning of the term *area*.

(2)

(b) The correct formula to calculate the perimeter of a rectangle is: (circle the correct option)

- A length × breadth
- B length + breadth
- C 2 length × 2 breadth
- D 2(length + breadth) (2)

(c) The correct unit of measurement for calculating area is: (circle the correct option)

- A cm³
- B mm²
- C mm
- D ml (2)

1.1.4 (a) Use a ruler to measure, in millimetres, the length and height of the completed Lego car in the picture below.



[Source: <<https://www.ebay.com/itm/134186108896>>]

Length = _____

Height = _____ (2)

(b) The diameter of one of the Lego car tyres is 14 mm. Calculate the radius of the tyre.





Radius = _____ (2)

(c) This Lego car is a scale model of a real car. The scale is given as 1 : 60.

Explain what the scale 1 : 60 means in this context.

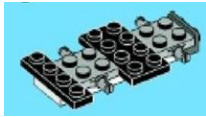
(2)

1.1.5 All Lego sets come with detailed instructions to help build the model. The four pictures below show how to begin the assembly of the Lego car. The pictures given are not in the correct order.

A	
B	
C	
D	

[Source: <https://lego.brickinstructions.com/en/lego_instructions/set/30183/Little_Car>]

Arrange the pictures in the correct order. Write the letter next to the correct number in the table below.

Example: 1. A

1	
2	
3	
4	

(4)

THIS PAGE HAS BEEN LEFT INTENTIONALLY BLANK

1.2 Stuart received some money for his birthday, and he asked his dad to take him to the Lego Store in Sandton City shopping mall. Below is a map of Sandton City.

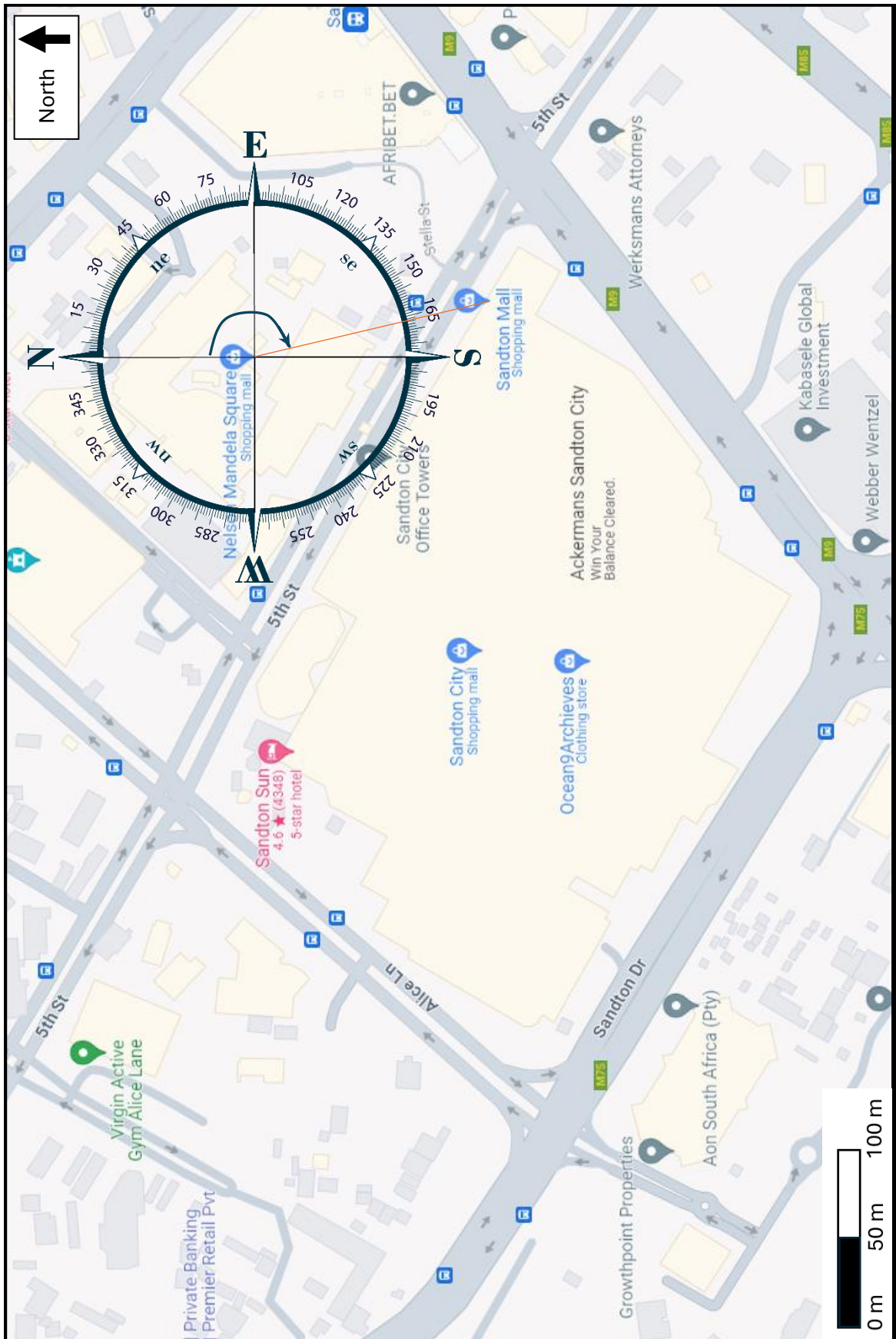

[Source: <<https://www.google.com/maps/place/Sandton+City>>]

Use the information on page 6 to answer the questions that follow.

1.2.1 Name the road on the Southwest side of Sandton City shopping mall.

_____ (2)

1.2.2 The M9 road runs on one side of Sandton City shopping mall. State what the letter M stands for on the road marked M9.

_____ (2)

1.2.3 Write down the type of scale shown on this map.

 _____ (2)

1.2.4 After shopping, they go to the Virgin Active gym in Alice Lane. Determine the compass direction of the Virgin Active gym from the Sandton City shopping mall.

 _____ (2)

1.2.5 Use the compass on the map to determine the angle between North and the Sandton Mall as shown by the arc on the compass.

 _____ (2)

1.2.6 Stuart notices a clock (see picture below) upon entering the gym. Write down the time shown on the clock using a 24-hour format, if they arrived after noon.



Time: _____

[Source: <<https://www.amazon.co.uk/Pyramid-Time-Systems-Analog-Clock>>]

(2)
[33]

QUESTION 2

2.1 The Makeba family plans to travel from Cape Town to Johannesburg for the Easter weekend. Mr Makeba has calculated that their route will be 1 394 km from Cape Town to Johannesburg. They will undertake this journey over two days, with an overnight stay in Bloemfontein. He used the two strip maps below to plan his route.

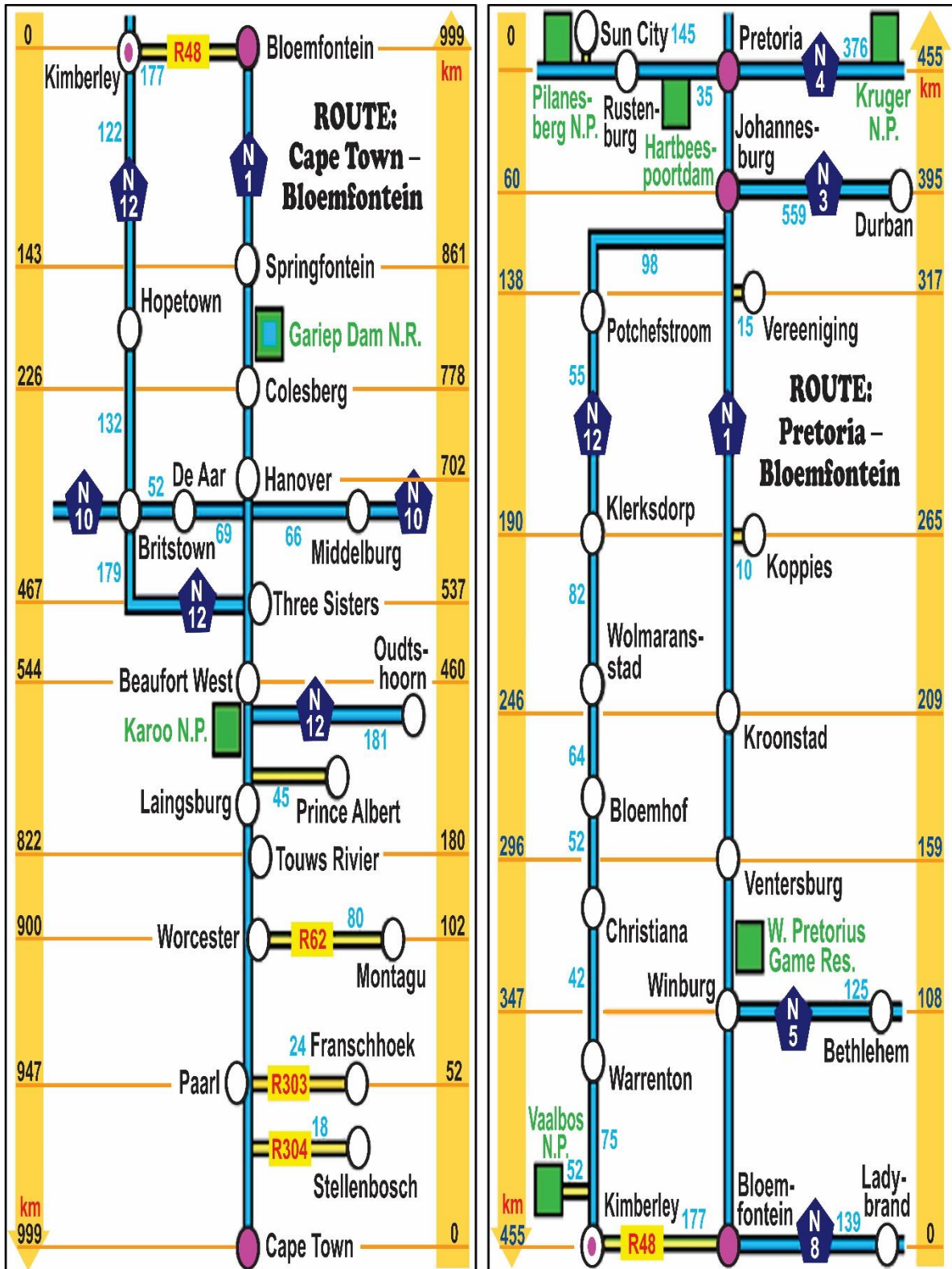

[Source: <<https://www.suedafrika.net/suedafrika-reise/reiserouten-suedafrika/bloemfontein-joburg.html>>]

Use the information and maps to answer the questions that follow.

2.1.1 State which national road they will travel along.

(2)

2.1.2 Name two towns, excluding Bloemfontein and Johannesburg, that they will travel through on Day 2 of their trip.

Town 1: _____

Town 2: _____ (2)

2.1.3 Show, using calculations, whether or not Mr Makeba calculated the route distance of 1 394 km correctly.

(3)

2.1.4 Calculate the percentage of the total trip they will cover on Day 1, rounded to the nearest whole percentage.

(3)

2.1.6 They leave Bloemfontein at 8:27 am with a full tank of diesel. They travel at an average speed of 100 km/h and only make one stop of 35 minutes along the route.

Calculate the time they will arrive in Johannesburg.

You may use the following formula:

$$\text{Time} = \frac{\text{Distance}}{\text{Speed}}$$

(4)

2.2 While in Bloemfontein, the Makeba family stays over at a hotel. A floor plan of their family suite is shown below.



[Source: <<https://lehner-belkaied.de/?o=top-design-hotel-hotels>>]

Use the above information to answer the questions that follow.

2.2.1 Show, using calculations, that 22' (feet) 2" (inches) is 675,64 cm if 1 foot = 30,48 cm and 1 inch = 2,54 cm.

(3)

2.2.3 The couch in the living room is a sleeper couch that converts into a double bed for the children.

Use the dimensions given in the diagram below to calculate the volume, in cm^3 , of the couch. Round off to the nearest 100 000.



[Source: <<https://decofurnsa.co.za/products/sofas-molly-fabric-sleeper-couch>>]

You may use the following formula:

$$\text{Volume}_{\text{rectangle prism}} = \text{length} \times \text{breadth} \times \text{height}$$

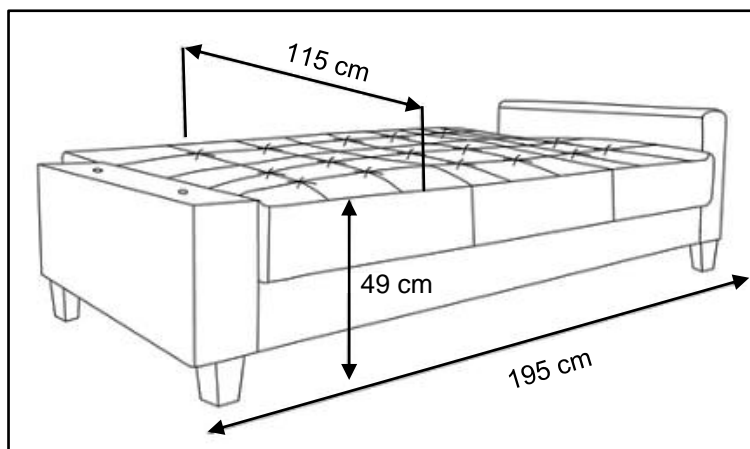

(3)
[34]

THIS PAGE HAS BEEN LEFT INTENTIONALLY BLANK

QUESTION 3

3.1 Padel, or padel tennis, is a fast-paced racquet sport that has recently gained popularity in South Africa. Many tennis clubs and schools are building courts, which are enclosed by metal meshed fences and clear glass. The shorter sides have clear glass topped with meshed fencing, while the longer sides feature four frames of clear glass with meshed panels. The rest of the walls are meshed fencing, except for the open entrances.

The dimensions of a padel court are shown in the diagrams below:

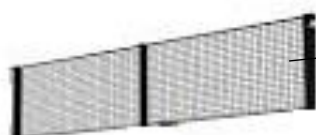
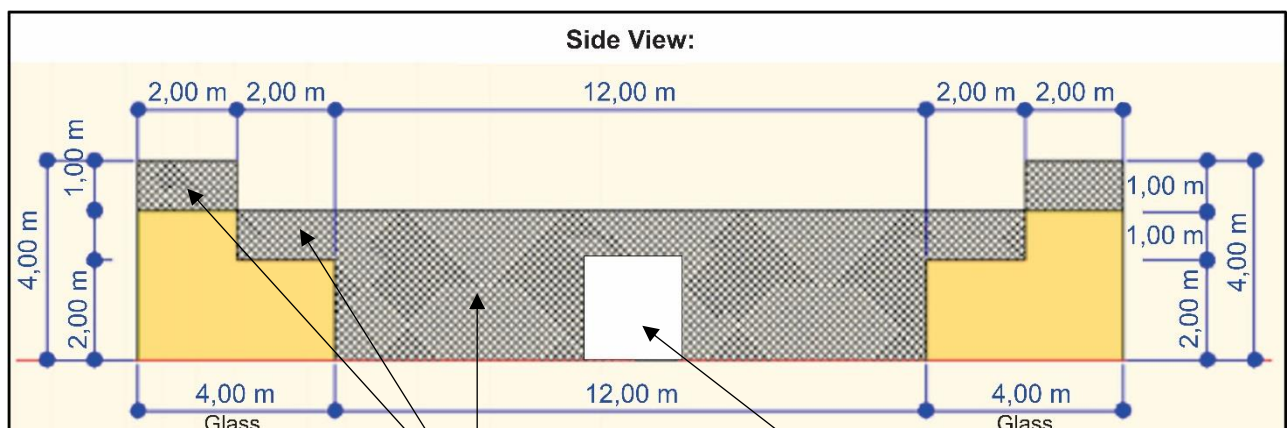
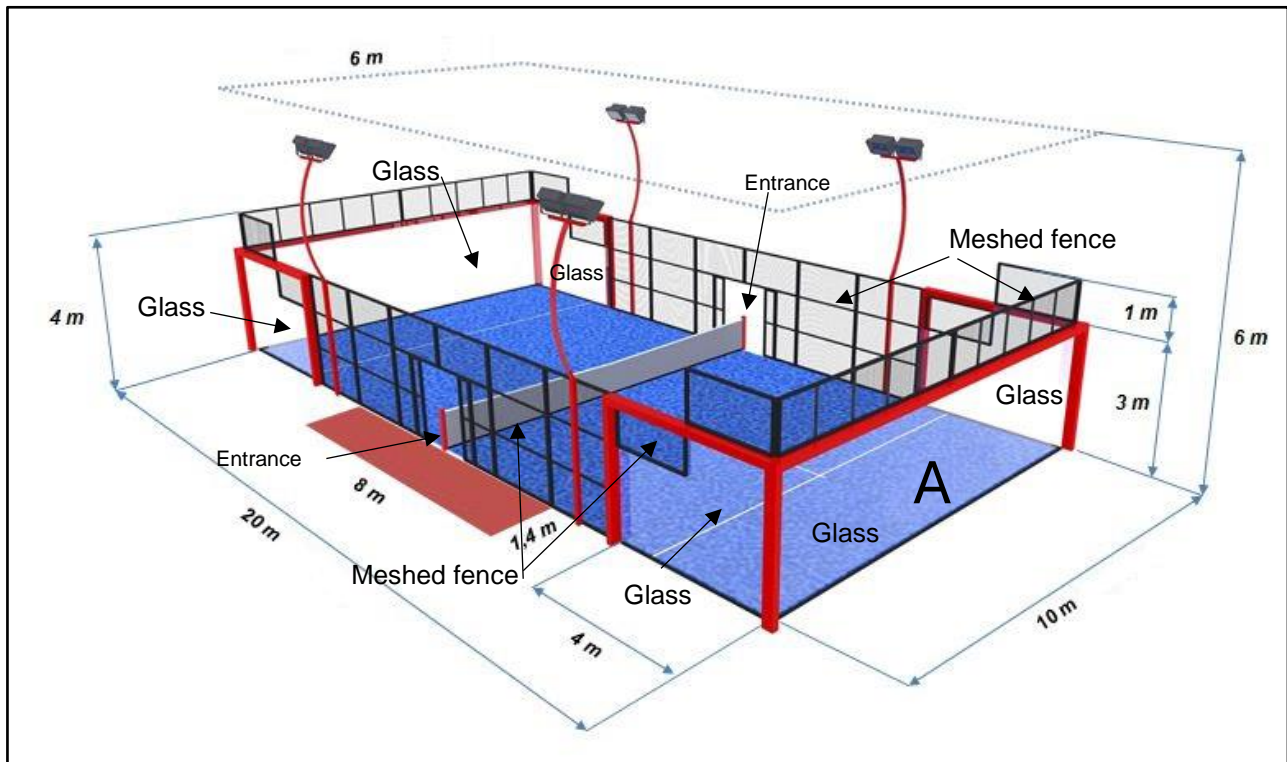

Meshed fence (no glass)

Entrance dimensions:
 Width = 0,82 m
 Height = 2,00 m

[Source: https://capetenniscourts.co.za/padel-court-measurements/]

3.1.1 Calculate the total surface area of the clear glass walls for this padel tennis court.

You may use the following formula:

$$\text{Area}_{\text{rectangle}} = \text{length} \times \text{breadth}$$

(5)

- 3.1.3 (a) Create a scale drawing of the front view wall labelled 'A' in the previous diagram. Select a suitable ratio scale for the drawing and ensure all dimensions are clearly indicated.

Draw the scale diagram in this space.

Scale _____

(4)

- (b) Give one advantage and one disadvantage of using a ratio scale.

Advantage: _____

Disadvantage: _____

(2)

3.2 A padel tennis racquet has no strings and is made from a carbon fibre frame and rubber core. The diagram with the dimensions of a round face padel racquet is shown below.



[Source: <<https://everythingpadel.co.uk/what-is-a-padel-racquet-made-of/>>]

3.4 The top three branded padel racquet manufacturers in South Africa are Head, Adidas, and Nox.

Each of these three manufacturers produce the following types of racquets: Diamond, Teardrop and Round racquets. See picture below.

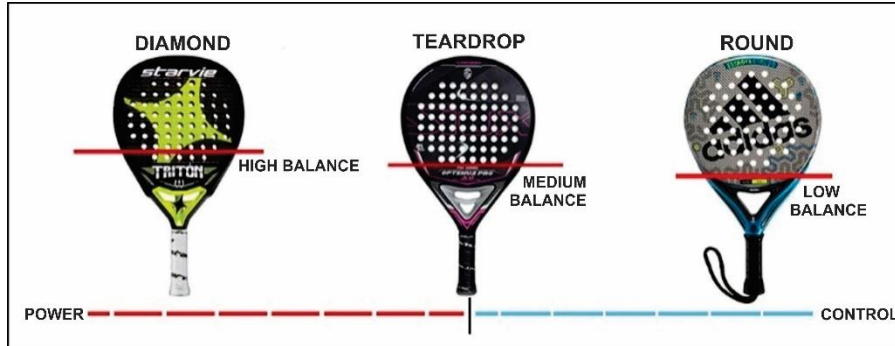

[Source: <<https://blog.padelnuestro.com/sv/padel-racquet-shape-and-size/>>]

(a) List all possible combinations of brand and racquet type that a player can choose from.

(3)

(b) Hence, calculate the probability of randomly choosing the round type of racquet from Head, if each of the racquets are equally likely to be chosen.

(2)

[38]

QUESTION 4

4.1 Mrs Naidoo is a dietician who works with children and parents to promote healthy eating habits. One of the measurements Mrs Naidoo uses is a child's Body Mass Index (BMI).

4.1.1 (a) State what the measurement of 33,4 kg represents.



[Source: <www.google/images.com>]

(2)

(b) The height chart alongside uses a boy's height in centimetres.

Write down, in metres, the height of the boy.

(2)

(c) Calculate this boy's BMI.

You may use the following formula:

$$\text{BMI} = \frac{\text{mass (kg)}}{\text{height}^2 \text{ (m)}}$$

(3)



[Source: <https://www.amazon.co.uk>]

4.1.2 Use your answer from **Question 4.1.1 (c)** and the BMI chart below to determine if the dietician would be happy with this BMI reading. Give a reason for your answer.

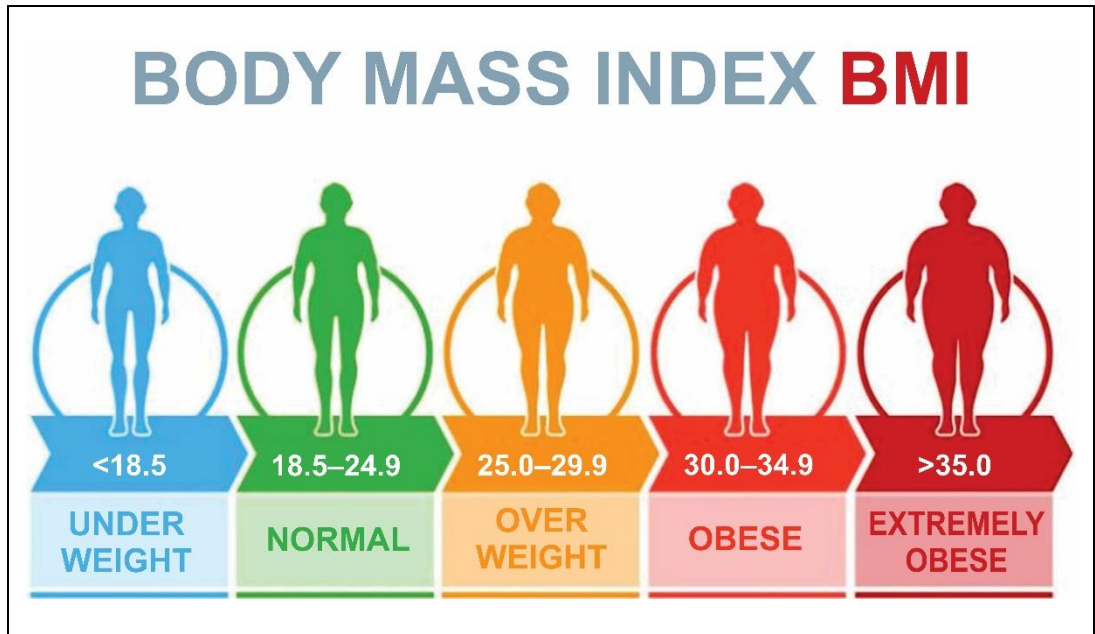

[Source: <<https://westmedical.com/bmi-calculator/>>]

(2)

4.1.3 Use your answer from **Question 4.1.1 (c)** and the growth chart below to determine the possible age of this boy.

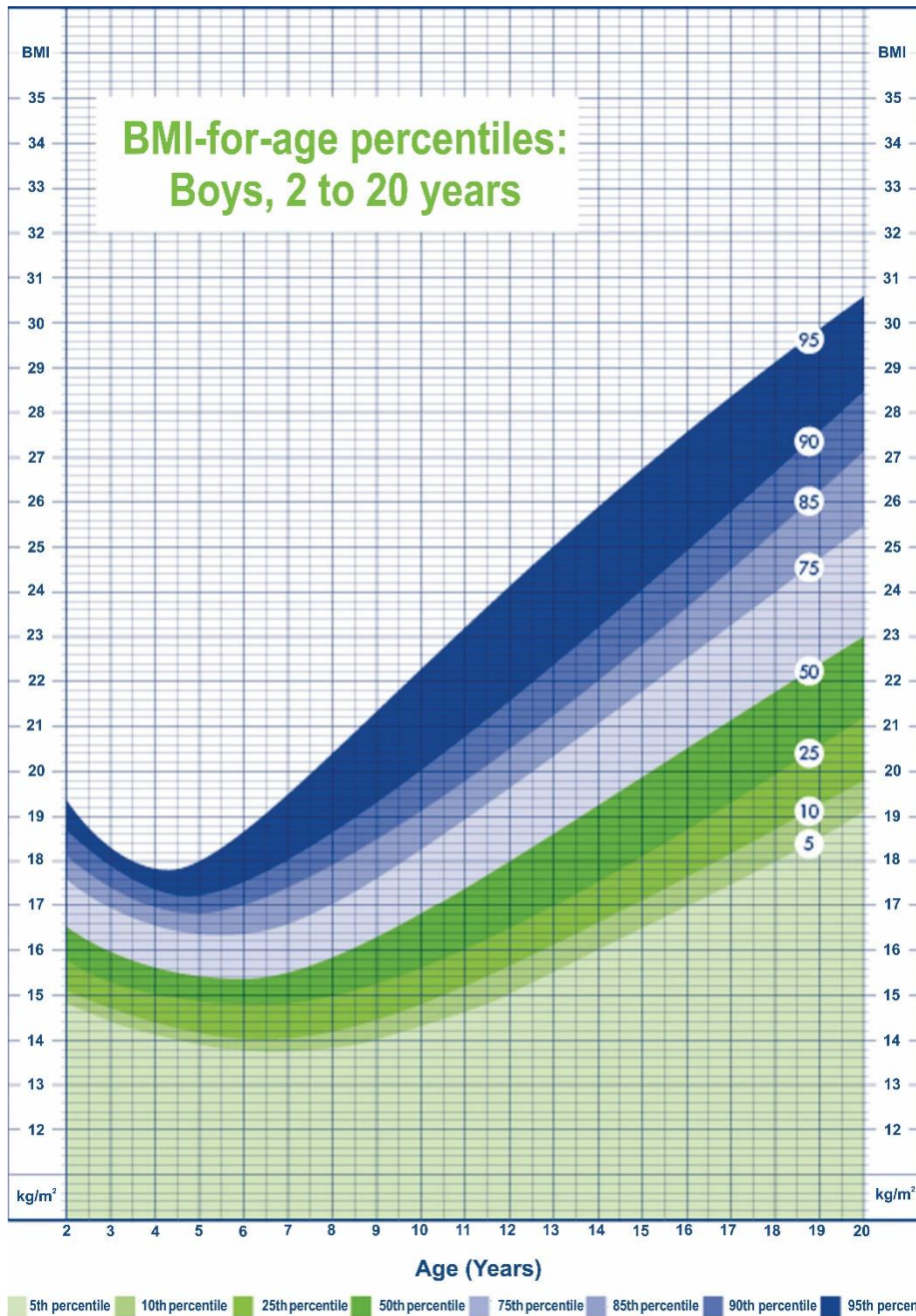

Weight Status category	Percentile range
Underweight	Less than 5th percentile
Healthy Weight	5th–85th percentile
Over Weight	85th–95th percentile
Obesity	95th percentile and greater

Highlight the ages on the chart and then write your answer in the following form:

Minimum–Maximum age. E.g. 40–45 years old.

(2)

4.2 The BMI chart below is for girls aged 2–20. Use the chart to answer the questions that follow.

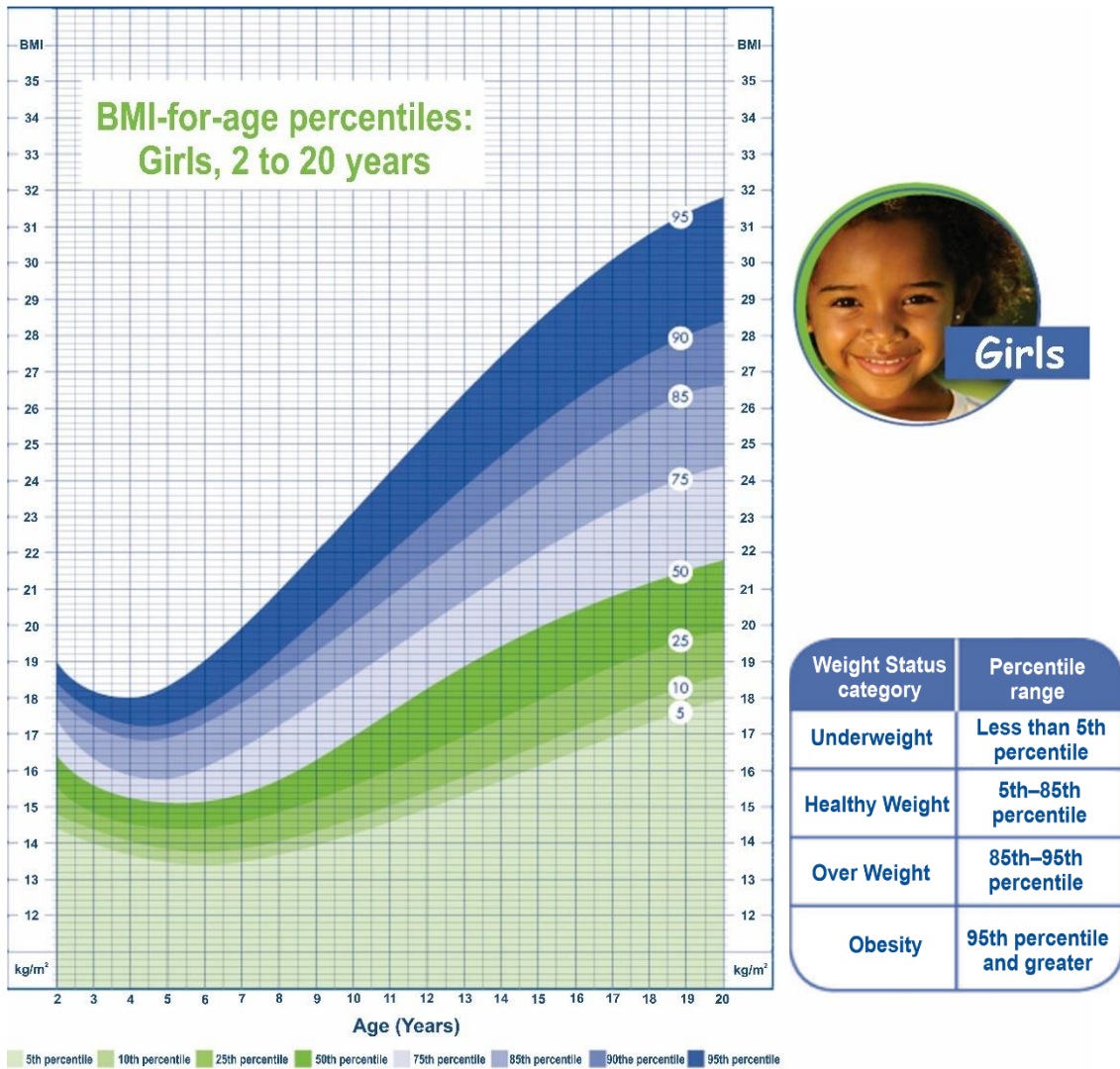

4.2.1 A 14-year-old girl has a BMI of 21. Mark on the chart, using a **large dot**, where you will locate her weight status. Now, write down the corresponding weight status category below.

_____ (2)

4.2.2 If the same girl has a mass of 45 kg, determine, in metres, her height rounded to two decimal places.

You may use the following formula:

$$BMI = \frac{\text{mass (kg)}}{\text{height}^2 \text{ (m)}}$$

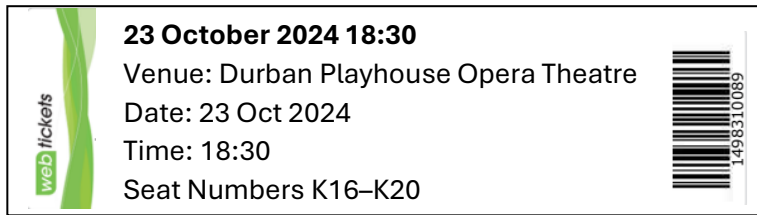

[Source: <<https://playhousecompany.com/>>]

Use the information above to answer the questions that follow.

4.3.1 How many people attended the play?

(2)

4.3.2 Use a highlighter or pencil to mark the seats booked by Mr Naidoo on the seating plan on page 28.

(2)

4.3.3 Mr and Mrs Naidoo arrive late, and the theatre is nearly full. Should they enter the theatre on the ground floor or first floor, and should they go left or right to find their seats? Justify your answer.

(3)

4.3.4 On the seating plan, there are three numbering errors. Circle these errors on the seating plan and then write the correct letters and numbers below.

(3)

4.3.5 The floor plan of the opera theatre foyer is given below.

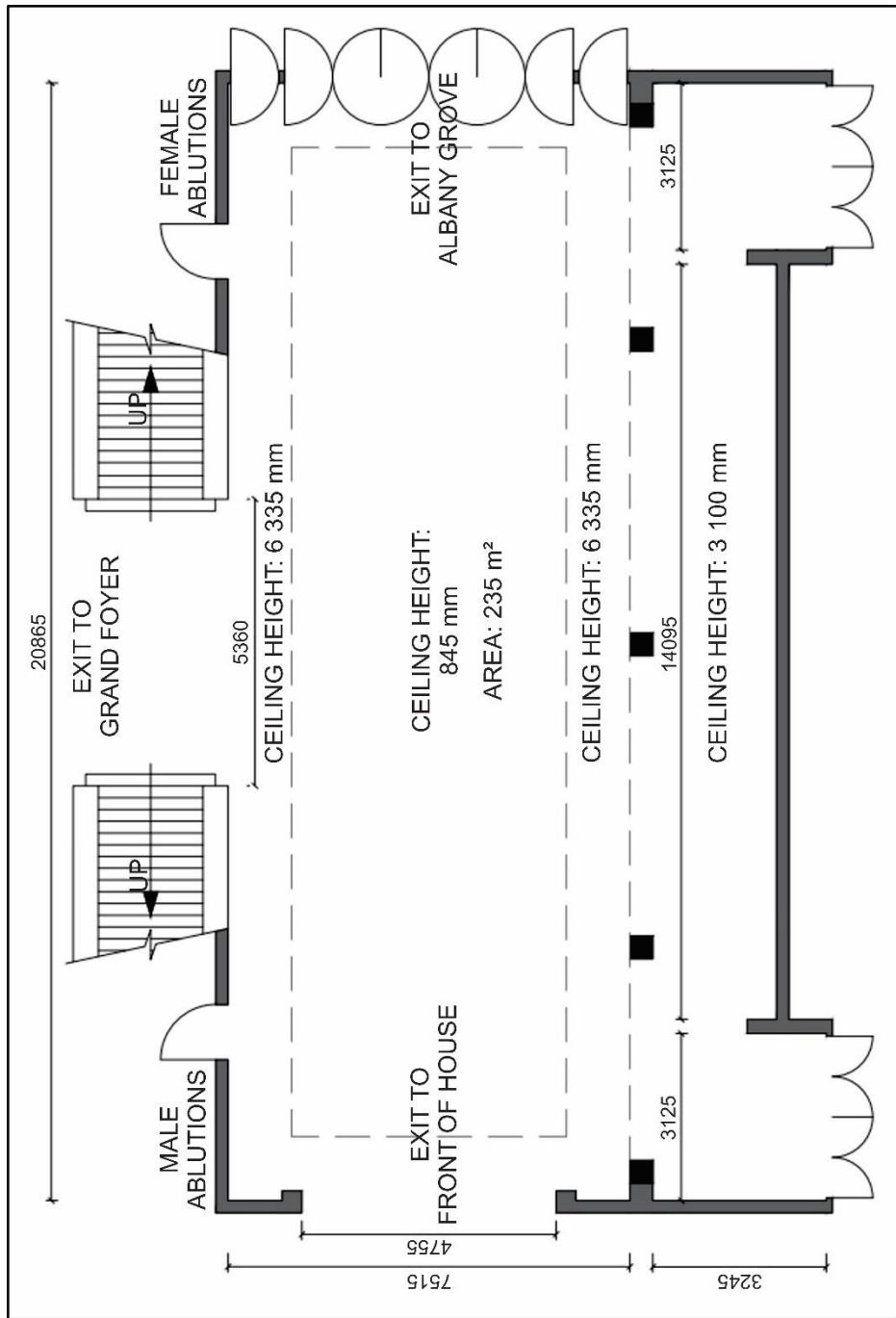

[Source: <<https://playhousecompany.com/>>]

Scale 1:100

Using the full length of the foyer (20 865 mm), show, using calculations, whether the given scale is correct.

(4)
[32]

THIS PAGE HAS BEEN LEFT INTENTIONALLY BLANK

QUESTION 5

5.1 Gavin Smith is looking after his young son while his wife is visiting her mother. Gavin's son is 3 years old and weighs 15 kg. He has not been feeling well for several hours. Gavin uses a medical thermometer to measure his son's temperature.

He gives his son doses of Calpol at regular intervals to control his fever.



Table showing dosage of Calpol for different ages.

Age	Average weight	Dose
Under 3 months	Not recommended	
3–6 months	6–8 kg	3,75 ml
6–24 months	8–12 kg	5 ml
2–4 years	12–16 kg	7,5 ml
4–6 years	16–20 kg	10 ml

May be given three to four times daily but with an interval of 4 hours between each dose.

Use the information above to answer the questions that follow.

5.1.1 Read and record Gavin's son's temperature on the thermometer.

(2)

5.1.2 Determine the dosage of Calpol that Gavin should give his son.

(2)

5.1.3 If Gavin administered his son's first dosage at 11:33 am, determine when Gavin can administer the second dose.

(2)

5.2 Gavin runs out of medicine and drives to the pharmacy to get more. The following pie chart shows the top four fever medications for children.

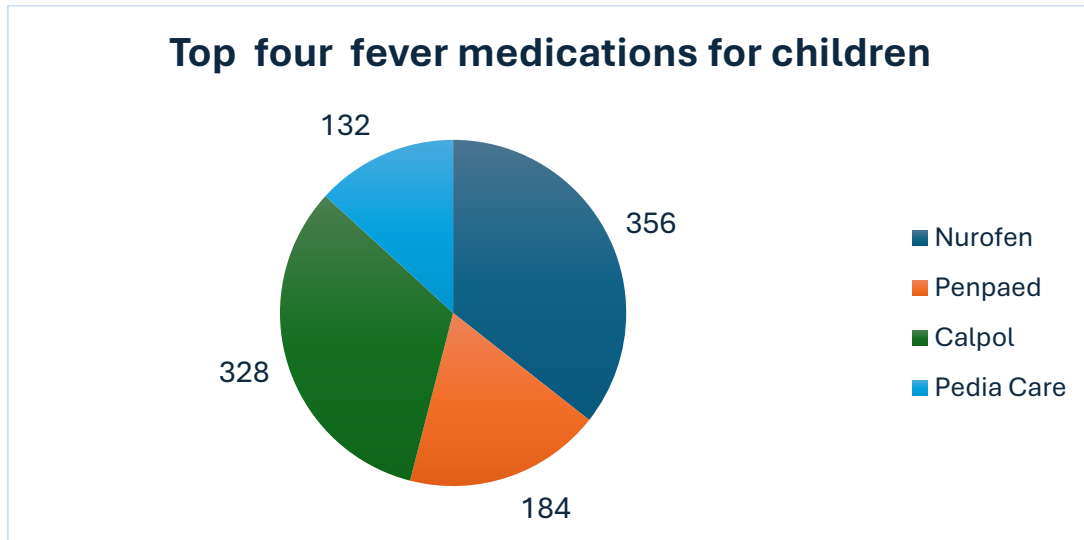

5.2.1 Determine, as a percentage, the probability that Gavin selected Nurofen if choosing any of them was equally likely.

(3)

5.2.2 Determine, as a decimal fraction, the probability that Gavin selects either Calpol or Pedia Care.

(4)
[13]

Total: 150 marks

PLEASE TURN OVER

